



www.spiro.ch

TUBEFORMER 1602 PRO



THE *Original* SINCE 1956

TUBEFORMER 1602 PRO

Spiro International S.A. pursued endeavors to enhance the value for tubeformer users even more. We believe that we accomplished this goal by introducing the Tubeformer 1602 PRO. Built upon the highly successful Tubeformer 1602 we have finetuned and reinforced components that will result in increased production capacity, material savings and higher functionality.



The production capacity can be increased by 38% as a result of a new automatic run-off table and patented super slitter combined with increased strip speed.

The patented “Bubblan” reel makes sure to produce a fixed lock seam and assured duct quality. The patented lubrication solution guarantees the production of almost grease-free and clean ducts. Moreover, the narrow lock seam solution generates material savings up to 3%!

A new generation of frequency controller applied at the main drive enables a smooth start and acceleration, resulting in almost soundless operation and minimized energy consumption. The combination of two years warranty and a Service Agreement reduces the risk of costly production interruptions and assures a continued process of high capacity, output quality, and reliability.

Unique Features	
Feature	Your Value
New Automatic Run-off Table	Increases production capacity by 38%
New Patented Super Slitter	
Increased Strip Speed	
Patented “Bubblan” Reel	Fixed lock seam and assured duct quality
Patented Lubrication Solution	Production of grease-free and clean ducts
Narrow Lock Seam Solution	Material savings up to 3%
Advanced Frequency Converter	Smooth start
2 Years Warranty	Risk minimisation
Service Agreement	Assurance of continued high capacity, output quality and reliability

TUBEFORMER 1602 PRO

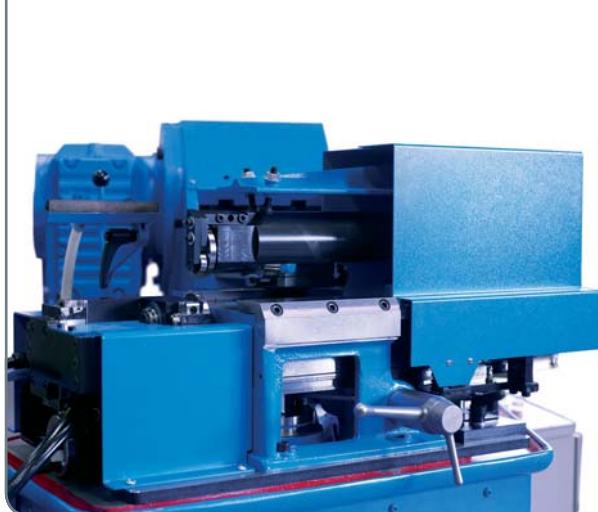

Technical Data

Diameter	80 - 1600 mm
Strip Thickness	0.4 - 1.5 mm galvanised steel 0.4 - 0.8 mm stainless steel 0.6 - 1.5 mm aluminium
Power Supply	15 kW / 3 phase / 400 V / 50 Hz (other voltage on request)
Strip Speed	Max. 100 m/min.
Duct Handling	Automatic run-off table. 6 metre duct length.
Cutting Systems Slitter - Smooth and Noiseless Cut	Standard up to 1.0 mm Heavy duty 1.1 mm - 1.5 mm Light duty for 80 mm diameter
Forming Heads	Cast aluminium forming heads, for long life and exact diameter (one required for each diameter)
Basic Machine	Frequency controlled main drive Monitoring production output Hydraulically controlled drive roller pressure Hydraulically operated clinching roller Automatic length measurement system
Decoilers	DCV 1200 vertical (max. 1 coil) or DCH 3000 horizontal (max. 3 coils)
Corrugation Attachment	1 Reinforcement bead 2 Reinforcement beads PLC controlled corrugation unit
Performance	273 Ducts per hour - 13.2 sec/tube (3 metre length / 160 mm diameter)

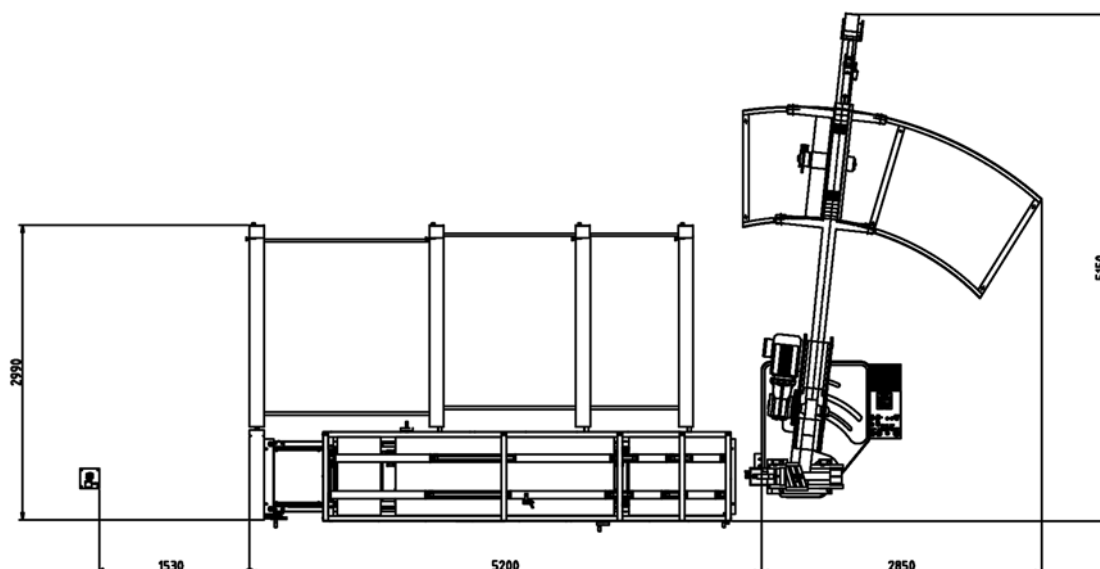

TUBEFORMER 1602 PRO



We welcome you to visit our demonstration centre to see the machines in action.



Spiro International S.A.

Industriestrasse 173 
CH-3178 Böisingen
Switzerland

Tel +41 31 740 31 00

Fax +41 31 740 31 31

E-mail info@spiro.ch

Web www.spiro.ch

THE COMPLETE SOLUTION



MACHINES

Spiro[®] can provide you with a complete set of superior quality machines for the production of circular ducts and fittings.



AIR DUCT SYSTEMS

Spiro[®] has an extensive range of pre-fabricated fittings, ventilation and air-conditioning accessories that make a great addition to the products your business can offer.



SERVICES

Spiro[®] have the experience, in depth knowledge, support and aftermarket services that ensure your production is continuous and efficient.