

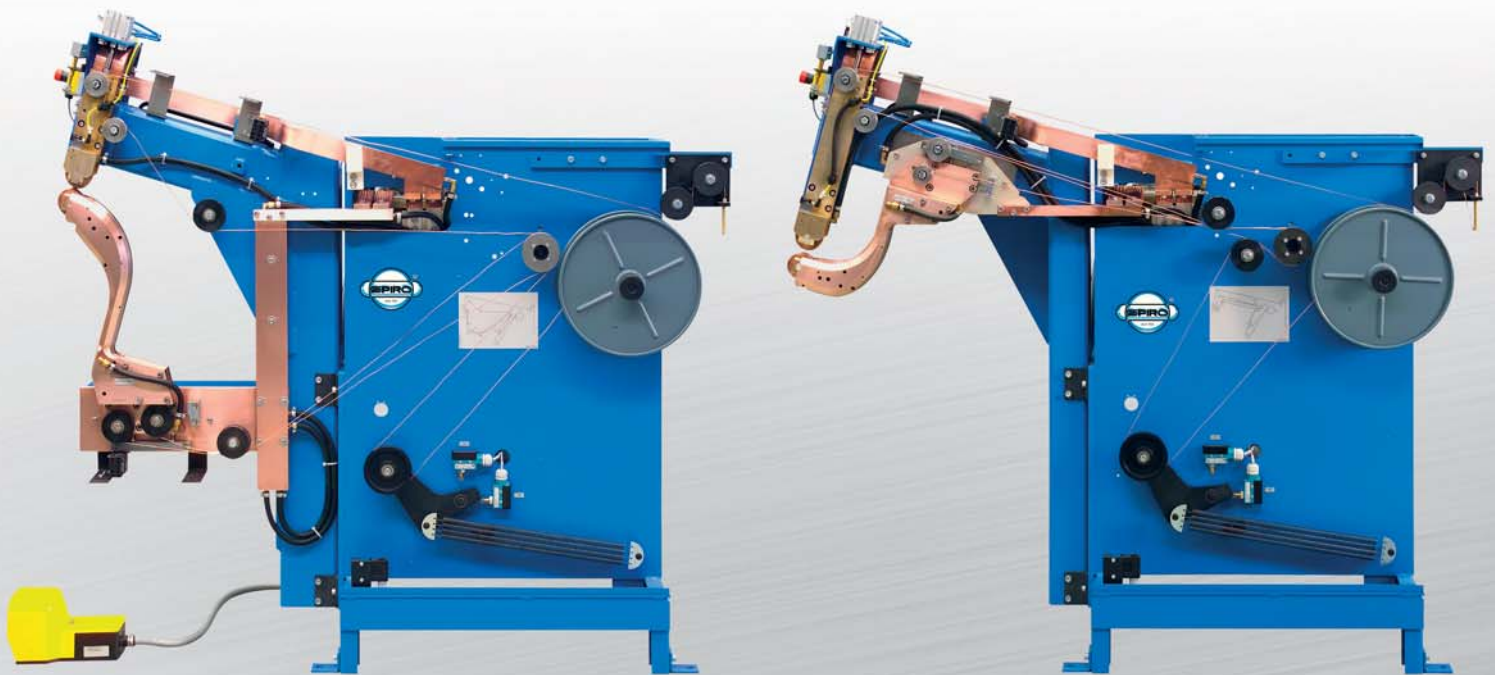

www.spiro.ch

STITCHWELDER SWB i/o



THE *Original* SINCE 1956

STITCHWELDER SWB i/o

The combination of SWB i/o allows the welding of pressed half-shells (inside and outside), covering the diameter range 80 - 315 mm (3 - 12"). It provides the possibility to weld both galvanised and stainless steel.

Unique Features

- » Simple operation
- » High reliability
- » Good accessibility of the components for fine adjustment
- » Variable welding speed
- » High safety level for operator and machine
- » Constant welding seam thanks to an intermediate copper wire electrode
- » Shortest possible change over times
- » Precise start and end welding points

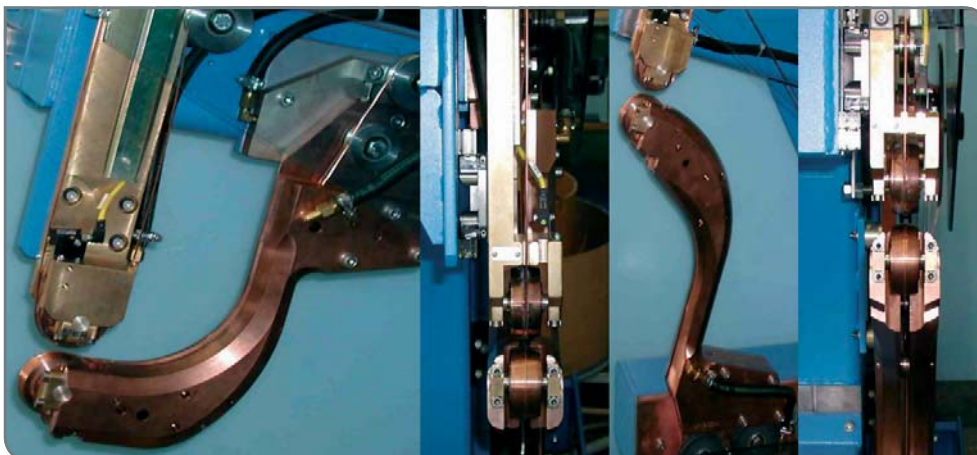

Without Overlap Setting Tools

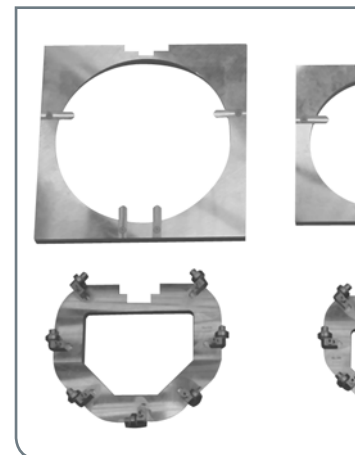

The SWB I welds the inner radius of the half-shells.
The SWB O welds the outer radius of the half-shells.

Technical Data	
Bend Diameter	80 - 315 mm (3" - 12")
Material Thickness	0.4 - 1 mm (0.015" - 0.039")
Seam Overlap	Variable
Copper Wire Diameter	2 mm (0.078")
Welding Speed	Variable between 2 and 9 m/min (10 - 30 fpm)
Power Supply	3 x 400 V, 50 Hz, 100 A (adapt to requirements)
Cooling System	Water cooling 12 litres/min (3 gallon/min) Water pressure at least 4 bar (58 PSI) Maximum water temperature for supply 15°C (59° F)
Compressed Air	6 bar (87 PSI) clean and dry air

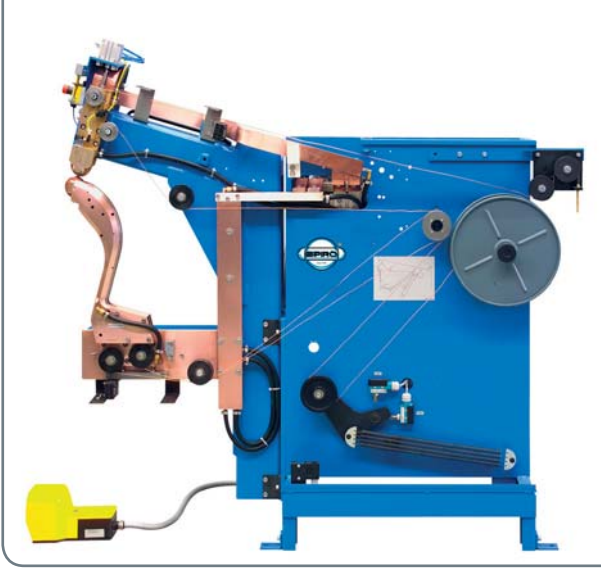

SWBo pictured with optional control unit

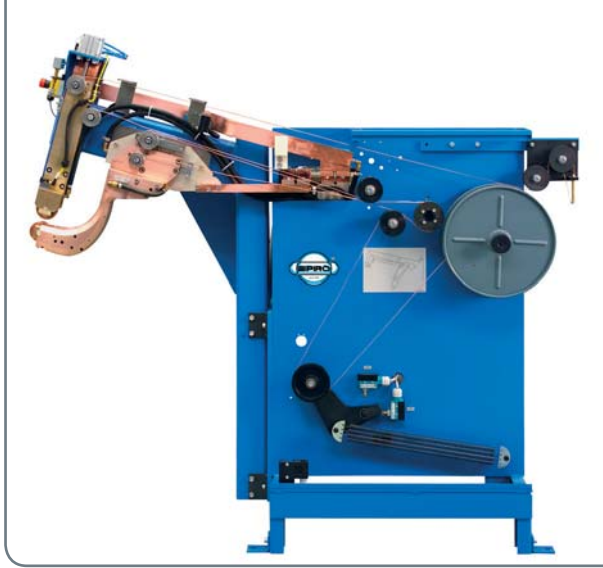

SWBi pictured without optional control unit

Overlap Setting Tools

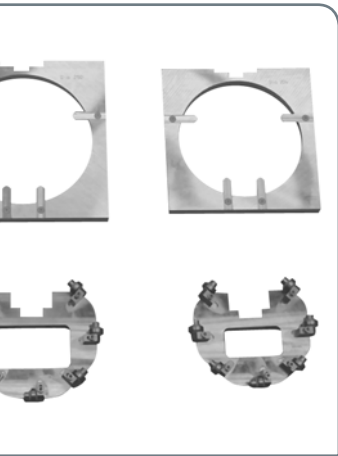

With Overlap Setting Tools

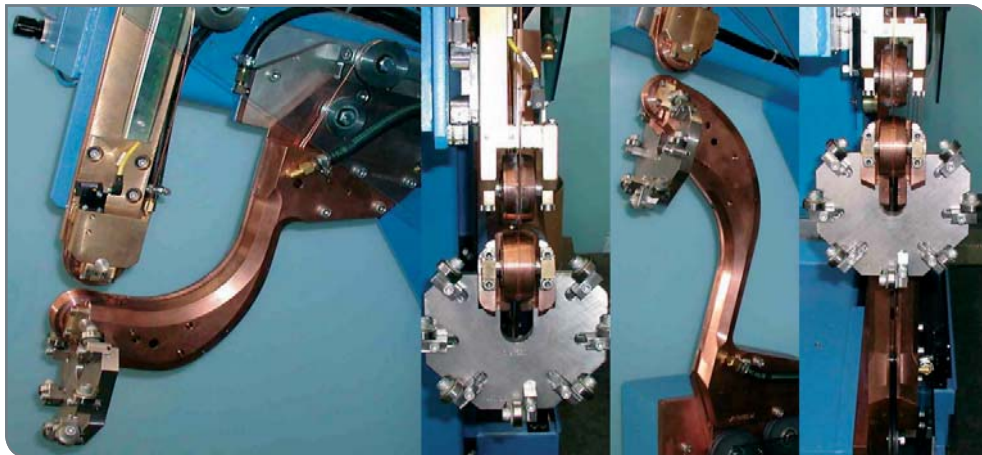

Contact Us

North America 

1450 Arthur Avenue
Suite B Elk Grove Village
IL 60007

Tel +1224-659-7870
Fax +1 224-659-7871
E-mail info@spiral-helix.com

SPIRAL-HELIX, Inc. 

Contact Us

Spiro International S.A. 

Industriestrasse 173
CH-3178 Böisingen
Switzerland

Tel +41 31 740 31 00
Fax +41 31 740 31 31
E-mail info@spiro.ch
Web www.spiro.ch



We welcome you to visit our demonstration centre to see the machines in action.



Spiro International S.A.

Industriestrasse 173
CH-3178 Bösingen
Switzerland

Tel +41 31 740 31 00

Fax +41 31 740 31 31

E-mail info@spiro.ch

Web www.spiro.ch



North America

1450 Arthur Avenue
Suite B Elk Grove Village
IL 60007

Tel +1 224-659-7870

Fax +1 224-659-7871

E-mail info@spiral-helix.com

SPIRAL-HELIX, Inc.

THE COMPLETE SOLUTION



MACHINES

Spiro[®] can provide you with a complete set of superior quality machines for the production of circular ducts and fittings.



AIR DUCT SYSTEMS

Spiro[®] has an extensive range of pre-fabricated fittings, ventilation and air-conditioning accessories that make a great addition to the products your business can offer.



SERVICES

Spiro[®] have the experience, in depth knowledge, support and aftermarket services that ensure your production is continuous and efficient.