



[www.spiro.ch](http://www.spiro.ch)

# CURVECUTTER DELTA 1500



THE *Original* SINCE 1956

# CURVECUTTER DELTA 1500

**This machine is specially designed for cutting out segments of highest accuracy from a blank.** The Curvecutter Delta 1500 is a suitable machine for a high production line together with the Spiro® Rollformer, Stitchwelder and Gorelocker.

## Unique Features

- » Select up to 9 different program settings ranging from 100 to 1500 mm diameter
- » Simple input for circular or flat-oval bends, angle cuts and insulation fittings
- » Accurate cutting of segments with high repeatability due to high-tech servo motors
- » No burrs and no hardening of the edge as a result of cutting with 4 roller-shears
- » Efficiency: 1 elbow 200 mm with 4 segments is cutting in 1 path within 15 seconds



Technical Data	
Maximum Sheet Width	1500 mm (60")
Material Thickness	0.4 - 1.1 mm (0,016" - 0,043") galvanised steel 0.4 - 0.6 mm (0,016" - 0,024") stainless steel 0.5 - 1.1 mm (0,020" - 0,043") aluminium
Cutting Speed	2 - 10 m/min. (6 - 32 fpm)
Segment Angle	5 - 46° (in steps of 1/10 degree)
Elbow Diameter	100 - 1500 mm (in steps of 1 mm) (4" - 60")
Number of Cutters	1 - 4 (selectable on control panel)

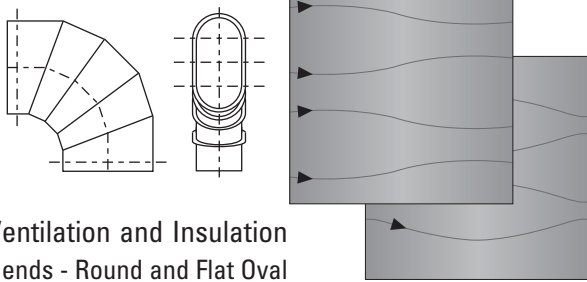
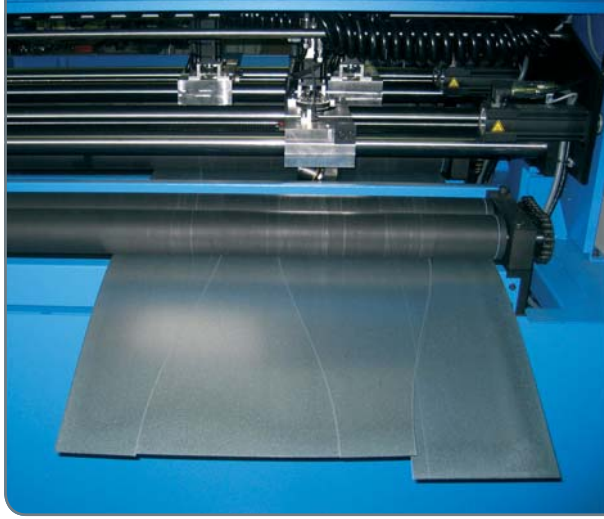
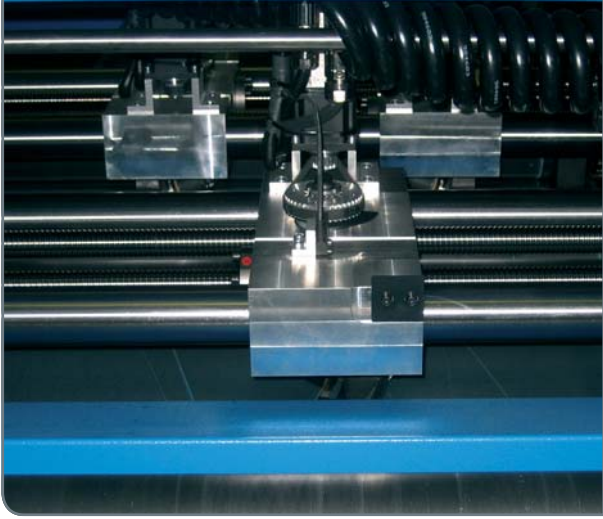

Ventilation and Insulation  
Bends - Round and Flat Oval

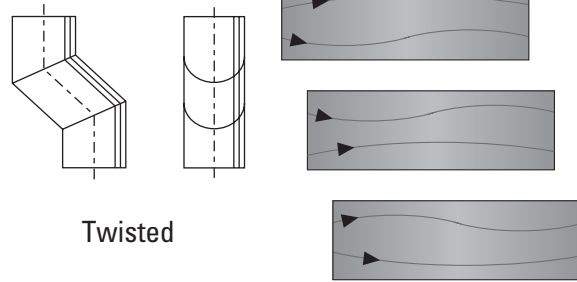

Twisted

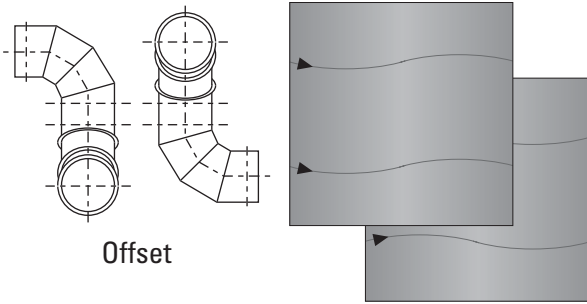

Offset

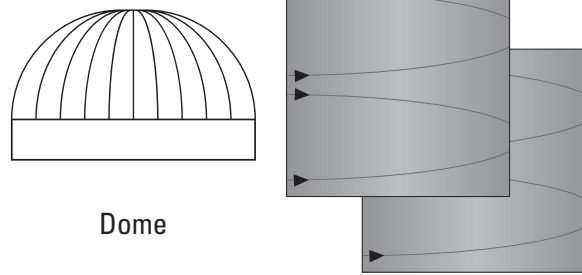

Dome

Program Display

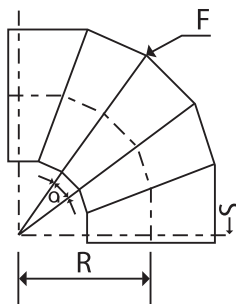



We welcome you to visit our demonstration centre to see the machines in action.



### Spiro International S.A.

Industriestrasse 173  
CH-3178 Bösinggen  
Switzerland

Tel +41 31 740 31 00

Fax +41 31 740 31 31

E-mail [info@spiro.ch](mailto:info@spiro.ch)

Web [www.spiro.ch](http://www.spiro.ch)



### North America

1450 Arthur Avenue  
Suite B Elk Grove Village  
IL 60007

Tel +1 224-659-7870

Fax +1 224-659-7871

E-mail [info@spiral-helix.com](mailto:info@spiral-helix.com)

**SPIRAL-HELIX, Inc.**

# THE COMPLETE SOLUTION



## MACHINES

Spiro<sup>®</sup> can provide you with a complete set of superior quality machines for the production of circular ducts and fittings.



## AIR DUCT SYSTEMS

Spiro<sup>®</sup> has an extensive range of pre-fabricated fittings, ventilation and air-conditioning accessories that make a great addition to the products your business can offer.



## SERVICES

Spiro<sup>®</sup> have the experience, in depth knowledge, support and aftermarket services that ensure your production is continuous and efficient.